

HD force

► User Manual | English



This user manual is available in PDF format at hdrehab.com and can be enlarged on screen.

CONTENTS

1. Warranty	4	4. Accessories	17
		4.1 Headrest and Neck rest	17
2. General information	5	4.2 Bag hook	17
2.1 Intended use	5	4.3 Thoracic support	18
2.2 General safety aspects	5	4.4 Belt mounts	18
2.3 Tests	6		
2.4 Wheelchair identification	7	5. Transport	20
2.5 Wheelchair parts	7	5.1 Folding the wheelchair for transportation	20
2.6 Delivery inspection	7	5.2 Transferring in and out of the wheelchair	20
2.7 Symbols and markings	7	5.3 Driving technique	21
3. Functions and settings	8	6. Maintenance and care	22
3.1 Brakes	8	6.1 Daily functional checks	22
3.2 Wheels	9	6.2 Long term storage	23
3.3 Tip protectors	9	6.3 Recycling and disposal	23
3.4 Push bar	10		
3.5 Cushions and covers	10		
3.6 Seat tilt and Back recline	11		
3.7 Backrest height	12	7. Technical data - Measurements	23
3.8 Setting the Flexi-back	12		
3.9 Adjustable seat depth	13		
3.10 Armrests	13		
3.11 Leg rests	14		
3.12 Calf supports	15		
3.13 Footrests	16		



**THANK YOU FOR CHOOSING A WHEELCHAIR FROM HD REHAB,
WE HOPE IT WILL SERVE YOU WELL**

WE MANUFACTURE QUALITY OF LIFE

HD Rehab helps people achieve an improved quality of life. Our products help make the lives of users, their families, and caregivers easier, safer, and more comfortable.

HD Rehab offers assistive products for people living with disability. Our primary product is wheelchairs, which we have been designing, developing, and manufacturing for over 40 years. We accept no compromises in quality. Precision, safety for user and caregiver, function, and design are our guiding principles. We are confident that you will feel the difference compared to any other wheelchair.

GLAD TO BE FLEXIBLE

Whether you are a user, a family member, or a caregiver we welcome your requests and opinions. Our designers and developers work closely with the production team at our facility on the island of Lidingö in Stockholm. Our creative employees use their specialist knowledge, experience, and inventiveness to find solutions for the unique needs of each individual.

1. WARRANTY

The warranty is only valid if the product is used as directed and the service and cleaning instructions are followed.

THE WARRANTY COVERS:

Frame	5 years against defects in materials, manufacturing and/or assembly.
Leg-/arm-/headrests	Two years against defects in materials, manufacturing and/or assembly.
Upholstery	Two years against defects in materials and faults in manufacture.
Gas springs	Two years against defects in materials and faults in manufacture.

WARRANTY & LIMITATION OF LIABILITY

HD Rehab assumes no liability for damages arising out of the following:

- That the instructions in the manual were not followed.
- Incorrect installation or setup by a third party other than HD Rehab.
- Unauthorized modifications or adaptations.
- Use of spare parts from other manufacturers than HD Rehab
- Use by persons weighing more than the maximum user weight stated on the wheelchair.
- That the wheelchair is adjusted to an inappropriate position or setting for the user.

2. GENERAL INFORMATION

HD Force is a class 1 CE labelled medical device.

2.1 Intended use

The wheelchair model HD Force 24 is a manual wheelchair designed for users who can propel themselves to a certain extent. This model can also be used by users who cannot propel themselves.

The wheelchair model HD Force 16 is a manual wheelchair designed for users who cannot propel the wheelchair themselves.

Both models are intended for use by users in need of much comfort and support when seated. The seat and back on both models can be tilted in various positions to give the user a varied position during activity and rest. A varied seat position is very important. Note that prolonged sitting without a position change can lead to discomfort and excessive pressure. If injury is suspected, look for information regarding symptoms and contact the health care system.

Use of a HD Force wheelchair requires a prescription from a medical professional. This applies to both new and used wheelchairs. Note that a new prescription may be needed if a user's disability changes or new needs arise. All prescription and adjustment of the wheelchair must be carried out by qualified personnel.

Where the wheelchair has several users, each patient's specific needs must be taken into account. In addition, the chair's upholstery on the back and seat cushions must be washed or changed for each user. Washing instructions are on the seat and cushion covers.

If the user has a pattern of movement or behaviour that strains the chair excessively a strengthened frame version and one piece footrest and calf support must be used. This includes users with significantly increased tonus/spasticity.

2.2. General safety aspects

HD Force is primarily intended for indoor use. Outdoor use can be very limited by the heavy weight of the user making the wheelchair difficult to maneuver, especially on uneven surfaces.

Before using the wheelchair, it is important that users and carers are familiar with how the chair works and how it should be used.

Test the driving characteristics and features.

- Read the whole manual and have it available. Note that deviations may occur especially if the wheelchair is specially equipped or adapted. The wheelchair may also be equipped with accessories and equipment from other suppliers.
- From a safety perspective, it is important to follow the maintenance instructions. See section **6 Maintenance and care**. A good rule is to keep the wheelchair clean and regularly test the controls and brakes.
- Be careful with all cables so that they do not get damaged. Particularly, when the chair has been transported it is good to do a further check to note that no cables have been damaged.
- If damage is detected or any component found to be missing the wheelchair must be taken out of service until this is fixed.
- The wheelchair should be operated and used judiciously to avoid unnecessary risks.
- The wheelchair is not intended to be operated by children.
- If the wheelchair is exposed to external heat sources such as sunlight some parts may become hot. Pay attention to this so that the user is not harmed.
- Be aware that certain items of clothing are not suitable as they may get caught in the wheels. Be especially careful with scarves and similar items that can tighten around the user's neck if caught.
- Sitting for long periods entails certain risks, e.g. circulation disorders such as thrombosis (blood clots). If such a problem is suspected, gather information regarding symptoms and contact medical care. A varied seating position throughout the day is important.

CUSHIONS

- Seat cushions made of foam have a limited lifetime depending on use. Cushions should be checked regularly and replaced as needed for the safety and comfort of the user. This helps avoid harm such as pressure sores. Only cushions designed to suit the weight of the user are to be used. If harm is suspected, gather information regarding symptoms and contact medical care. See also section **6 Maintenance and care**.

TIPPING RISK

- Do not hang bags, oxygen bottles, or other items on the seat back, especially when the chair is fully tilted back.
- Some users have involuntary movements, or are very active, and want to grab hold of solid objects (e.g. door frames). Use caution with these users and ensure that you are aware when their behaviour can tip the wheelchair. Avoid parking near fixed objects.

PINCHING RISK

- As the wheelchair has many different configuration options the caregiver must be alert to the user's position in the chair, to avoid the possibility that the user could be pinched. The risk of pinching is small under normal circumstances.
- Keep in mind that the user cannot always communicate that a pinching injury is occurring.

LIFTING

This advice is general since there are many different lifting aids available.

- When lifting in and out of the wheelchair be very attentive that the user's arms and legs do not get caught. Fold in the footrests or remove them so that they do not get in the way. Follow the lifting aid instructions carefully.
- Training is often required to operate the lifting aid.

CE MARKED ACCESSORIES, CUSTOMIZING

- HD Rehab has a number of CE-marked accessories that are authorized for use with the wheelchair while maintaining the CE marking. Accessories that have not been approved may not be used.
- Any change to the wheelchair or use of accessories that are not certified and CE-marked by HD Rehab is a special adaptation and a transfer of liability occurs. Specially adapted wheelchairs do not retain CE marking and the warranty is void. Always consult HD Rehab if unsure about what applies. Help is available for special adaptations for individual users.

DAILY FUNCTIONAL CHECK

To ensure that the wheelchair works as it should, a daily function test should be performed before the user is positioned in the seat. See section **6.1 Daily functional check**.

REPLACEMENT PARTS AND SERVICE

If the wheelchair is in need of replacement parts or service contact the reseller.

SAFETY NOTICES AND PRODUCT RECALLS

Information regarding any safety notices and product recalls can be found at hdrehab.com.

WARNINGS

In addition to these general safety aspects there are warnings and notices contained in each section in the manual. They are marked with a warning triangle as follows:



- Here is the warning.

2.3 Tests

Wheelchair tests have been carried out for HD Force at RISE Research Institutes of Sweden, Borås, Sweden (ISO 7176-19:2008 and EN 12183:2014, and ISO 7176-19 respectively). Resistance to ignition tests have been carried out at Swerea IVF, Mölndal, Sweden (ISO 7176-16:2013, EN 1021-1, and EN 1021-2). More information and certificates are found at hdrehab.com.

2.4 Wheelchair identification

Manufacturer, production year, serial number (SN), and article number (REF), in text and in bar code format, are printed on the front cross tube of the wheel frame, see Figure 1.

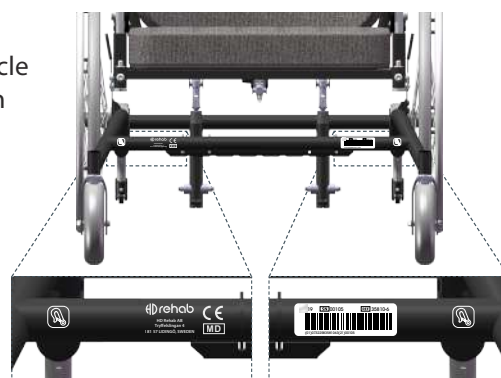

Figure 1. Labels for wheelchair identification

2.5 Wheelchair parts

- | | |
|-------------------|--------------------------|
| 1 Wheel frame ● | 9 Push bar |
| 2 Seat frame ● | 10 Tip protector |
| 3 Back frame ● | 11 Leg rest |
| 4 Back system ○ | 12 Calf support |
| 5 Drive wheel | 13 Foot rest |
| 6 Castor | 14 Armrest, side support |
| 7 Caregiver brake | 15 Balance plate ○ |
| 8 User brake | |

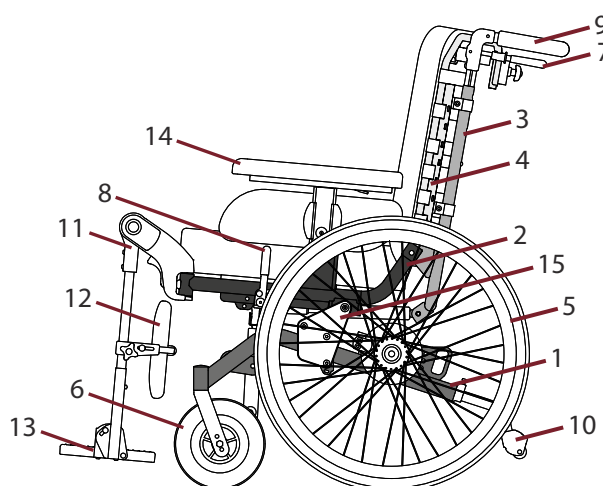

Figure 2. The parts of the wheelchair

2.6 Delivery inspection

Always do the following on delivery:

- Check that the wheelchair does not have any visible damage.
- Report any shipping damage to the transport company immediately.

Follow the unpacking instructions that come with the delivery. This may be supplemented with further instructions depending on the how the wheelchair is equipped.

2.7 Symbols and markings

The following markings are on the wheelchair. For more detail see document *Labelling*, doc.nr. 97760-1.

HD force

24 < 54 >

Model label. Shows that the model is HD Force, as well as the wheel size and seat width of the wheelchair.

HDrehab

HD Rehab AB
Tryffelslingan 4
181 57 LIDINGÖ, SWEDEN

CE

MD

SN

REF

CE-marking. Shows that the wheelchair is a CE marked medical device and who the manufacturer is. SN stands for Serial Number and REF for article number.



Parking brake. Shows how the sleeve on the brake lever is moved to activate the parking brake.



Transport attachment. Marks the anchor points for transport.



Max user weight. Shows the maximum user weight for the wheelchair.



Attention required. Wheelchairs with alternate configurations or are equipped with accessories that carry increased or different risks are marked with this symbol.

3. FUNCTIONS AND SETTINGS

3.1 Brakes

HD Force is equipped with combined service- and parking- disc brakes that can be activated by both the caregiver (1 in Figure 3) and the user (2 in Figure 3).

CAREGIVER BRAKES

The brakes are activated by the caregiver behind the wheelchair by pushing the handles (Figure 4) up towards the push bar. Holding the brake handles slightly pressed achieves a braking effect, for example when moving downhill.

The parking brake is activated by pressing the brake handles up towards the push bar and then moving the locking sleeve (a in Figure 5) forward so that the brake handle is locked in place.

NOTE: Make sure the locking sleeve is pushed forward sufficiently so that it sits securely.

NOTE: Always use both left-hand and right-hand parking brakes together.

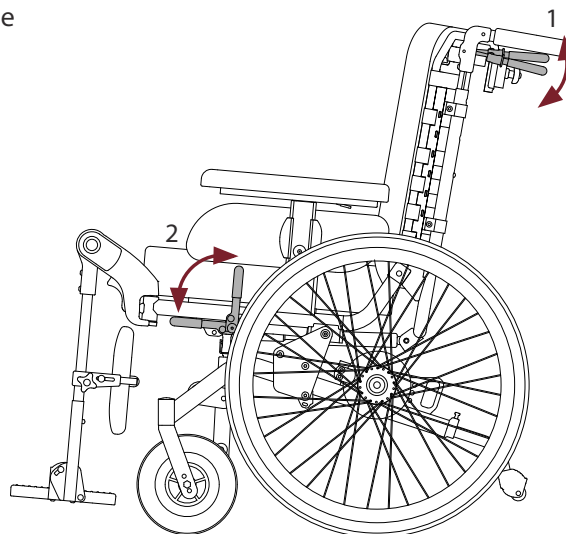

Figure 3. Caregiver brakes and user brakes

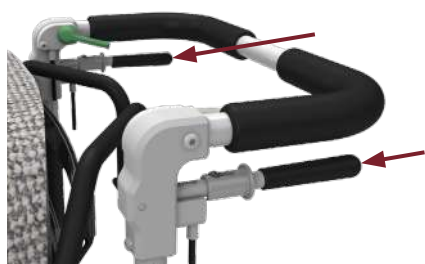

Figure 4. Brake handles

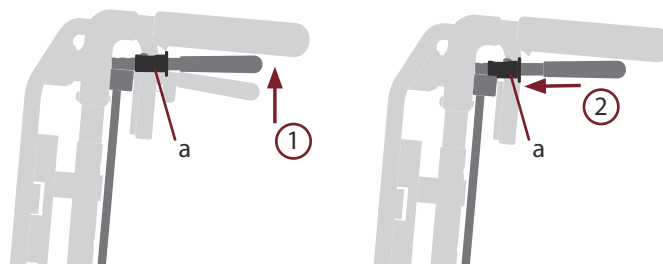

Figure 5. Parking brakes

USER BRAKES

The user can engage the brakes by moving the brake levers forward from the wheels. The brakes are released by moving the brake levers back towards the wheels.



- Parking brakes are not suitable for use when the wheelchair is on a surface that slopes more than 7°.



- Adjustment of the disc brakes should only be done by a qualified technician.

3.2 Wheels

HD Force is equipped with either 24" or 16" drive wheels depending on model and design. All drive wheel tyres are solid Flexel as standard and equipped with quick releases. The castors are 200 mm as standard.

Alternatively, the wheelchair can be equipped with pneumatic tyres.

REMOVING THE WHEEL:

- Press the lock button (1 in Figure 6) on the top (HD Force 24) or the bottom (HD Force 16) of the wheel mount, pull off the wheel.

MOUNTING THE WHEEL:

- Insert the axle (3) in the wheel mount housing (2), see Figure 6.
- Press the lock button (1) on wheel mount.
- Press the wheel so that the three pins on the hub fit in to the three holes in the brake disc.
- Release the lock button and check that the wheel is secured by pulling on it.



Figure 6. Wheel removal



- Make sure the lock button has slid out and the wheel is fixed.
- Be careful not to allow the user's hands to go in to the wheels.
- Be aware that certain items of clothing are not suitable as they may get caught in the wheels. Be especially careful with scarves and similar items that can tighten around the user's neck if caught.
- If pneumatic tyres are equipped the recommended air pressure is indicated on the tyres, normally 300 kPa.

3.3 Tip protectors

Tip protectors are standard equipment on HD Force and should always be used. The tip protectors can be set in three positions by means of a snap lock, see Figure 7. The snap lock is released by pulling the pin (1, Figure 7). It is possible to temporarily turn up the tip protectors temporarily, for example when passing over a curb, see Figure 8.

The tip protector can also be used as a tipping bar, providing resistance for the operator's foot when the wheelchair is tipped back on the rear wheels. The antitip devices are slightly different between the 24" and 16" models.



- Always ensure that the snap lock locks firmly into place so that the antitip device is locked.
- Make sure that correct model of tip protector is used for the wheelchair. They are marked with name and article number.



Figure 7. The 3 positions for the tip protectors



Figure 8. Tip protector turned up

3.4 Push bar

HEIGHT ADJUSTMENT OF THE PUSH BAR:

- Grip the push bar with one hand.
- Press in one snap lock (1 in Figure 9) and pull the push bar up on the same side.
- Hold the bar up and push the second snap lock (2).
- Set the push bar to the desired position.
- Ensure that both snap locks have sprung out into the holes.
- Check brake and control cables run freely and have not been damaged. They should run along the back tubes.



Figure 9. Push bar release buttons

3.5 Cushions and covers

Seat and back cushions are attached with velcro and are easily removable and interchangeable.



- Check cushions regularly according to the maintenance instructions. Worn out cushions can cause pressure ulcers.

POSITIONING THE SEAT CUSHION:

- Align the cushion over the seat plate and place it straight down. The back of the cushion is labelled. The underside is flat.
- Check that the cushion sits securely.

REMOVING THE SEAT CUSHION:

- Grasp the front edge of the cushion and pull straight up.

POSITIONING THE BACK CUSHION:

- Fully release the top strap of the Flexi-back (2 in Figure 10)
- Attach the straps (3) at the top of the cushion around the Flexi back's tubes (1) with velcro as shown. Securing the cushion vertically reduces the risk of the cushion sliding down when moving in to and out of the wheelchair.
- Pivot the cushion downward and press firmly against the back (Figure 11).
- Check that the cushion is placed correctly and sits securely.
- Reset the top strap of the Flexi-back, preferably with the user seated.

REMOVAL OF BACK CUSHION:

- Pull up on the lower edge of the cushion
- Loose the straps at the top.

REMOVABLE COVER

Both the seat and back cushion covers are fitted with a zipper for easy removal and replacement. Washing instructions are on the label.

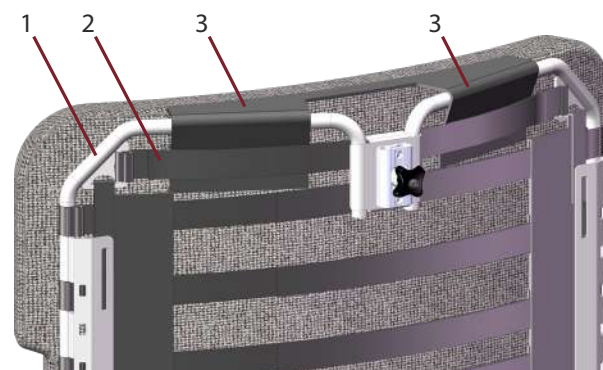

Figure 10. Straps fastened around Flexi-back

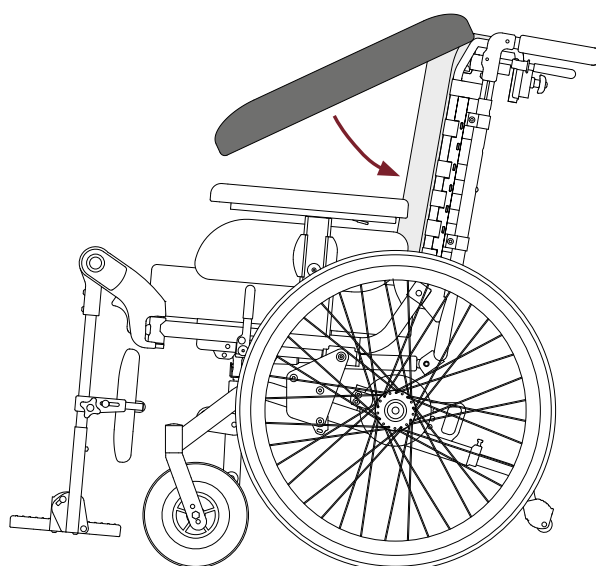

Figure 11. Setting the back cushion

3.6 Seat tilt and Back recline

Figure 13 shows the wheelchair in back reclined and seat tilted positions.



- The controls should be handled with moderate force and should always be used one at a time, **never** both at the same time.
- Never hang items on the levers.

SEAT TILT

The seat tilt is controlled by the green lever on the right side of the push bar, 1 in Figure 12. The seat can be tilted continuously between 0° and 20°.

Two gas cylinders provide supporting force when tilting backward. Note that the seat will feel heavy to tilt forward if no one is sitting in the wheelchair.

OPERATING THE SEAT TILT:

- Grip the push bar with both hands.
- Release the lock by pressing the green lever down gently, hold it down.
- Push on the push bar to set the desired seat tilt, release the green lever.

BACK RECLINE

The back recline angle is controlled by the gray lever on the left side of the push bar, 2 in Figure 12. As standard the back can be reclined continuously 30°, between 90° and 120°. A gas cylinder provides supporting force when raising the back. Note that this means the back will feel heavy to recline backward if no one is sitting in the wheelchair.

OPERATING THE BACK RECLINE:

- Grip the push bar with both hands.
- Release the lock by pressing the gray lever down gently, hold it down.
- Push on the push bar to set the desired back recline angle, release the gray lever.



- Risks exist for some accessories when adjusting recline angle, for example pinching towards the table when raising the back. Similar risks also appear for belt, pommel and hemiplegic armrest.



Figure 12. Controls for seat tilt (1) and back recline (2)

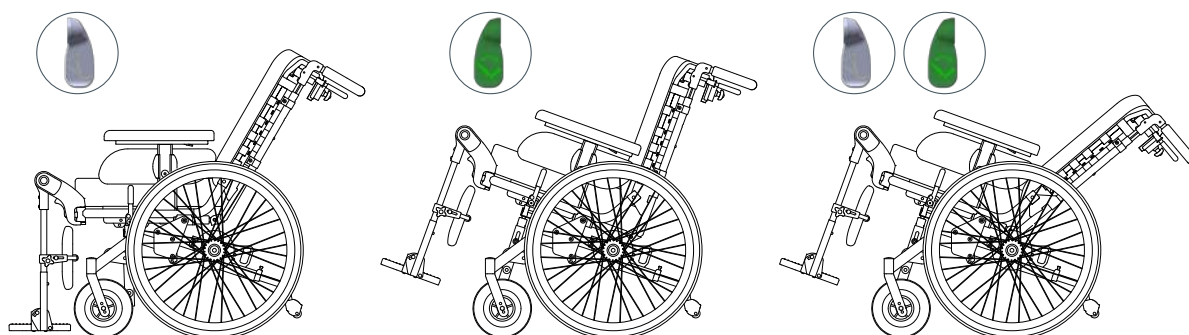

Figure 13. Three positions: Max back recline, max seat tilt, and both recline and seat in max position

3.7 Backrest Height

The backrest height can be adjusted approximately 5 cm in the tracks where the back support is secured. This requires a 10mm spanner.

As an alternative for tall users there is an extended backrest that is 10cm higher than standard.

HEIGHT ADJUSTMENT OF THE BACKREST:

- Loosen the two nuts on each side a few turns (1 in Figure 14).
- Push the backrest up or down to the desired height.
- Tighten the nuts securely.
- Check carefully that all cables are whole and in place.



Figure 14. Nuts for height adjustment

If the backrest needs to be even higher, the four clamps the Flexi-back is attached to are moved upward along the back frame tubes. This makes the backrest position 25 mm higher. Steps:

- Loosen the four back clamps by loosening the screws a few turns (Figure 15).
- Push the back clamps carefully along the back frame tube to the desired position. Some risk of damage to the paint finish exists. *Note that the top position for the push bar becomes unusable because the snap hole is covered.*



Figure 15. Back clamp screws

3.8 Setting the Flexi-back

Guide for setting the Flexi-back:

1. Before the user sits in a wheelchair;

- Release the velcro straps of the Flexi-back.
- Pull the back cushion off the velcro straps, leaving it attached to the top of the Flexi-back. Fold the back cushion lengthwise. Hold it folded and push it back against the straps. Release.
- Make sure the back cushion is properly positioned in the chair. See instructions under **3.5 Cushions and covers**.
- Loosen the nuts for height adjustment of the Flexi-back.

2. Positioning the user;

- When lifting the user, tilt the wheelchair's seat unit backwards. In some cases it is also helpful to recline the backrest slightly.
- Position the user well into the wheelchair, between the side tubes of the Flexi-back. This is required to form the Flexi-back to the user's back.
- **Note:** The user's position affects the driving and tilt characteristics of the wheelchair, especially with a heavy user.

3. With the user sitting in the wheelchair;

- Set the backrest at the desired height.
- Tighten the nuts for the seat back height adjustment.
- Adjust the velcro straps to support the user's back.

3.9 Adjustable seat depth

The depth of the seat plate can be continuously adjusted in a 10 cm range. It is secured by two knobs under the seat.

SETTING SEAT DEPTH:

- Loosen the two knobs a few turns (Figure 16).
- Slide the seat plate to the desired position.
- Firmly tighten the two knobs.
- Check that the seat plate is securely locked.

The seat plate can be pulled out, for maintenance reasons, by removing the knobs completely.



Figure 16. Seat plate knobs

3.10 Armrests

Armrests are placed in mounts on each side of the seat (Figure 17). They can be adjusted in height and depth.

Components, see Figure 18:

- 1 Armrest pad
- 2 Side support
- 3 Locking button
- 4 Locking lever

HEIGHT ADJUSTMENT:

- Push the button (3 in Figure 18) and hold it in.
- Set the desired height. The post is marked with 1 cm intervals.
- Release the button and pull lightly on the armrest pad so the lock snaps in place.

DEPTH SETTING:

The armrest pad can be adjusted to six depth settings as standard. It may not be possible to use the rearmost positions if the wheelchair has a special design, such as a wider Flexi-back.

- Press the locking lever (4 in Figure 18) and set the desired position.
- Release the locking lever.
- Make sure the armrest pad is locked in position by pulling lightly on it.

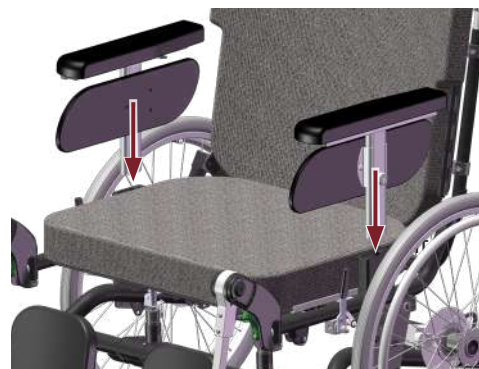

Figure 17. Armrests are inserted into the brackets on each side of the frame

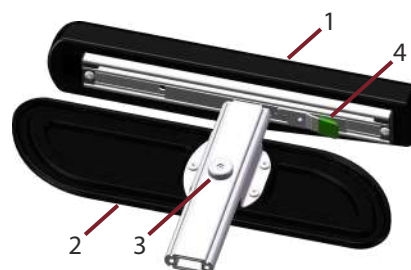

Figure 18. Armrest components

3.11 Leg rests

FIXED-ANGLE LEG RESTS

Fixed-angle leg rests are available in two versions, 90° and 105°.

Components, see Figure 19:

- 1 Knee joint
- 2 Leg rest tube
- 3 Locking lever, leg rest removal
- 4 Snap lock, footrest height adjustment

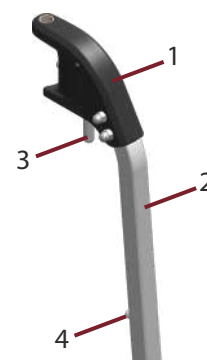

Figure 19. Fixed-angle leg rest

MOUNTING FIXED-ANGLE LEG REST

- Align the hole in the knee joint over the peg and let the knee joint slide down (Figure 20). It may be easier if the lever (1) is pressed forward.
- Release the lever and rotate the leg rest to point straight ahead, make sure that the locking pin clicks in and locks the knee joint.

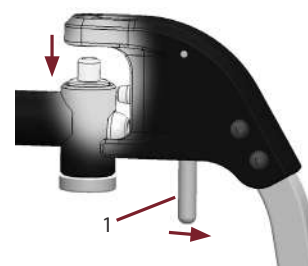

Figure 20. Mounting of leg rest

REMOVAL OF FIXED-ANGLE LEG REST

- Grip the leg rest and move the lever (1 in Figure 20) forward.
- Lift off the leg rest.

TURNING OUT LEG RESTS

If the wheelchair is equipped with separate footrests and separate calf supports the leg rests can be turned out for better access in and out of the chair. Grip the knee joint from above and press the locking lever, then turn the leg rest out (Figure 21).



Figure 21. Turning out legrest

ANGLE ADJUSTABLE LEG RESTS

The wheelchair may be equipped with angle adjustable leg rests. They can be angled between 90° (straight down) and 180° (straight out) with 10° steps (a total of 10 positions).

Components, see Figure 22:

- 1 Release button, angle adjustment
- 2 Knee joint
- 3 Turnable link
- 4 Locking lever, leg rest removal
- 5 Leg rest tube
- 6 Snap lock, footrest height adjustment

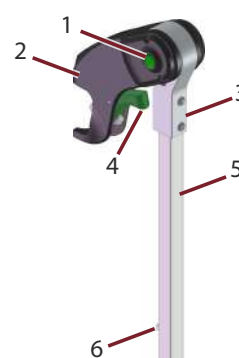

Figure 22. Angle-adjustable leg rest

MOUNTING ANGLE ADJUSTABLE LEG REST

- Grip the knee joint and press the locking lever (1 in Figure 23).
- Move the knee joint just above the mount on the wheelchair.
- Align the knee joint with the peg and slide it down (2).
- Ensure that the locking pin clicks in.

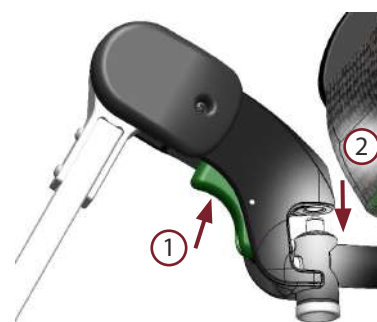

Figure 23. Mounting of leg rest

REMOVAL / TURNING OUT OF ANGLE ADJUSTABLE LEG RESTS

- Grip the leg rest from above and press the lever in (1 in Figure 23).
- Lift off the leg rest.

If the wheelchair is equipped with separate footrests and separate calf supports the leg rests can be turned out for better access in and out of the chair. Grip the knee joint from above and press the locking lever, then turn the leg rest out (Figure 21).

ANGLE ADJUSTMENT OF LEG RESTS

- Grip the leg rest tube at the bottom (1 in Figure 24). Lift slightly to ease the pressure on the locking mechanism.
- Push button on the outside of the knee joint (2) and move the leg rest to the desired position (3).
- Release the button and move the leg rest in either direction so that the mechanism snaps into a locked position.

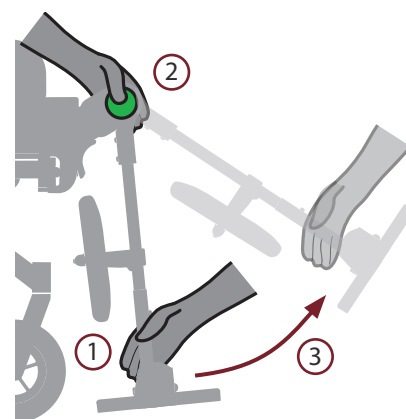

Figure 24. Angling of leg rest

3.12 Calf supports

DEPTH SETTING OF ONE PIECE CALF SUPPORT

- Loosen the lock nut a few turns (1 in Figure 25) on both sides.
- Slide the calf support to the desired position.
- Tighten the nuts securely.

HEIGHT ADJUSTMENT OF ONE PIECE CALF SUPPORT

- Loosen the knob (2 in Figure 25) on both sides.
- Slide the calf support to the desired position.
- Tighten the knobs securely.

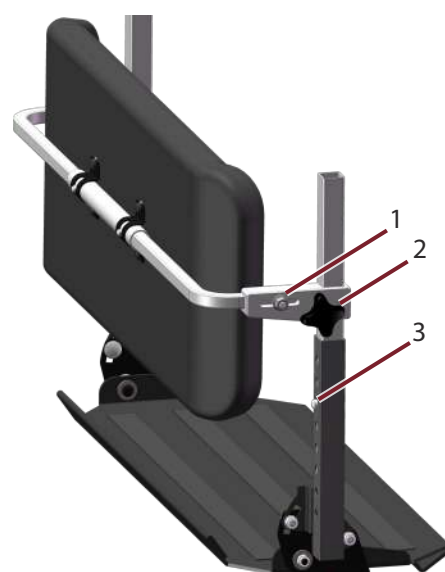

Figure 25. One-piece calf support

DEPTH SETTING OF SEPARATE CALF SUPPORT

- Loosen the lock nut a few turns (1 in Figure 26)
- Slide the calf support to the desired position.
- Tighten the nut securely.

HEIGHT ADJUSTMENT OF SEPARATE CALF SUPPORT

- Loosen the knob (2 in Figure 26).
- Slide the calf support to the desired position.
- Tighten the knob securely.

LATERAL ADJUSTMENT OF SEPARATE CALF SUPPORT

- Loosen the screw a few turns (3 in Figure 26).
- Slide the calf support to the desired position.
- Tighten the screw.



Figure 26. Separate calf support

3.13 Footrests

HEIGHT ADJUSTMENT OF ONE-PIECE FOOTREST

Push in the snap locks (1 in Figure 27) on both sides and move the footrest to the desired position.

ANGLE ADJUSTMENT OF ONE-PIECE FOOTREST

- Loosen the lock nuts (2 in Figure 27) on both sides.
- Move the footrest to the desired angle.
- Tighten the nuts securely.

FOLDING UP ONE-PIECE FOOTREST

The foot plate can be folded up to make it easier to get in-to and out-of the wheelchair (Figure 27).

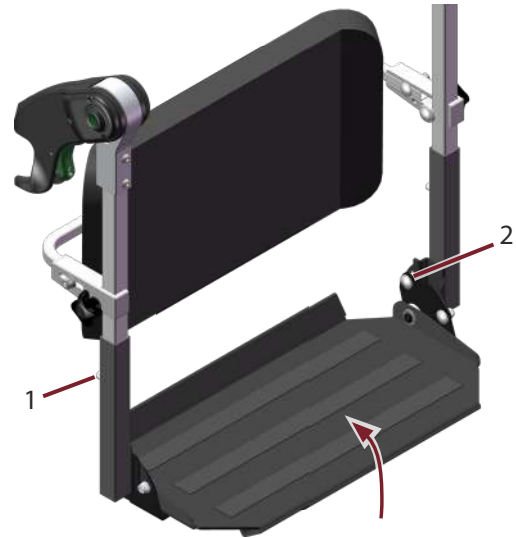

Figure 27. One piece footrest

HEIGHT ADJUSTMENT OF SEPARATE FOOTRESTS

Push in the snap lock (1 in Figure 28) and move the footrest to the desired position.

ANGLE ADJUSTMENT OF SEPARATE FOOTRESTS

- Loosen the bolt (2 in Figure 28).
- Move the footrest plate to the desired angle.
- Tighten the bolt securely.

FOLDING UP SEPARATE FOOTRESTS

The foot plate can be folded up to make it easier to get in-to and out-of the wheelchair (Figure 29).



Figure 28. Separate footrest



Figure 29. Folding up the footrest

4. ACCESSORIES

The following sections briefly describe the accessories that are available for HD Force. They are all CE-marked and approved for use with the wheelchair. More information about each accessory is available on the respective information sheet. Instructions for installing each accessory are found on the respective accessory assembly instructions. More info is available at hdrehab.com.



- Never use accessories that are not approved for HD Force. The wheelchair is then considered a specially adapted product. Read more in 2.2. **General safety aspects**.

4.1 Headrest and Neck Rest

Headrests (Figure 30) and Neck rests consist of two parts, a mounting profile (1) and a cushion (2) with a mount. The cushion somewhat smaller for the Neck rest than the Headrest.

The mounting profile is placed through the bracket on the backrest (3 in Figure 30) and secured in place by tightening the knob (7).

Note: Over-tightening the knob may cause damage.

LATERAL ADJUSTMENT

Some headrest models can be adjusted laterally to suit the user.

- Loosen the bolts (6 in Figure 30)
- Move the headrest to the desired position, tighten the bolts.

The cushion is shaped to provide support at the base of the skull so that the head can be positioned in a balanced and comfortable position.

SIDE SUPPORTS FOR HEADREST AND NECK REST

Some models of headrest and neck rest can be equipped with one or two removable side supports (4 in Figure 30) to increase lateral stability. In this case the back of the main headrest comes with two mounts (5) to adjust the positions of the side supports.



- Do not hang things on the headrest, it will increase tipping risk.
- For users with particular/involuntary movements there is a risk of getting caught between the headrest and the wheelchair. An individual assessment must be done to determine what type of headrest is suitable for the user.

4.2 Bag hook

The bag hook (Figure 31) is mounted on the back frame. The hook is clamped to the tube by tightening a screw.

The maximum load for each hook is 5 kg. The total load when two hooks are used should not exceed 5 kg as tipping risk is significantly increased.

Always be careful that no parts of the wheelchair are damaged with the use of a bag hook, particularly the brake and control cables.

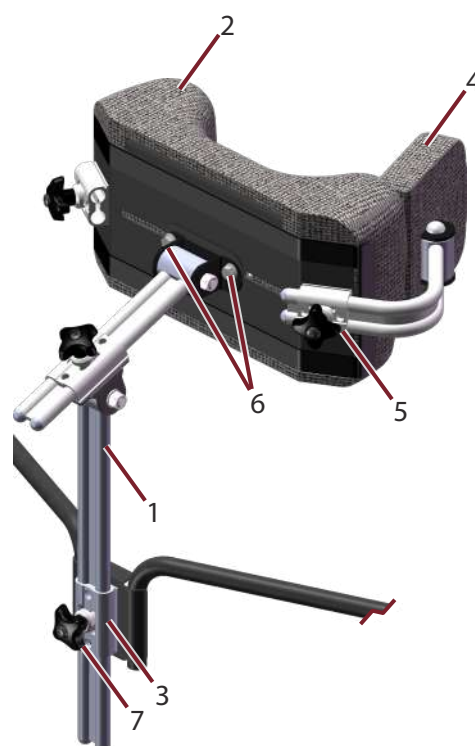

Figure 30. Headrest components



Figure 31. Bag hook

4.2 Thoracic support

The thoracic support is mounted by inserting the profile (1 in Figure 32) in the thoracic support mount (2) on the backrest. It is secured at the desired position with a knob (3). **Note:** Do not tighten too hard, the knob and mount can be damaged.

Thoracic support is available with or without Swing-away function. With Swing-away the cushion can easily be swung off to the side by pushing the button (4). **Note:** If the user presses heavily against the support the button is difficult to push.

The removable cover is attached with velcro. Washing instructions are on the label.

SETTINGS

The thoracic support can be adjusted in height and depth to create a good fit against the body. Some models also allow adjustment of the shape of the cushion. See the Thoracic support user manual for details.

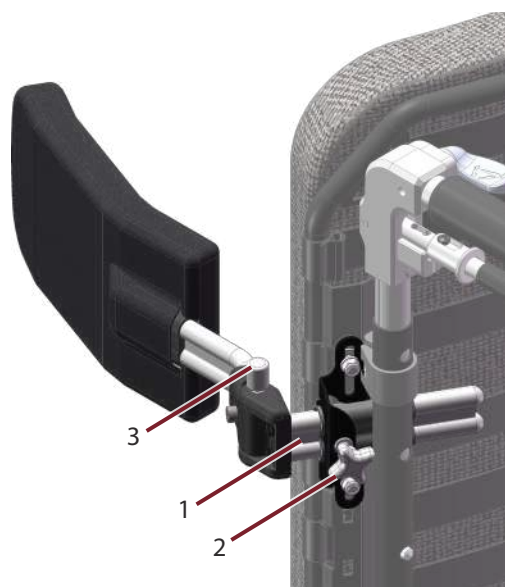

Figure 32. Thoracic support with mount



- Note that the use of the thoracic support requires careful adjustment to ensure the user receives good support and that the thoracic support does not cause pressure that can lead to injury.
- Avoid placing the thoracic support near the armpit as the area is generally considered to be intimate and pressure sensitive.

4.3 Belt mounts

To position the user in the wheelchair a belt can be used. HD Force can be equipped with belt mounts at the thighs (1 in Figure 33) and at the hips (2). Always follow instructions in the manual for the belt in use.

MOUNTS FOR 2-POINT BELTS

2-point belts are attached to two belt mounts, one on each side. The mounting points can be at the thighs or at the hips, depending on the needs of the user. It is important that the mounts be placed correctly so the user is well positioned. They should be installed by qualified personnel.

MOUNTS FOR 4-POINT BELTS

4-point belts are attached to four belt mounts, two on each side. It is important that the mounts be placed correctly so the user is well positioned. They should be installed by qualified personnel.

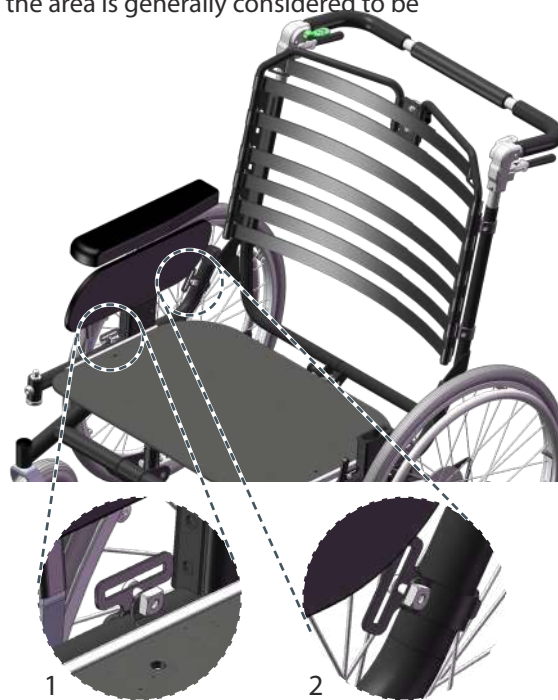

Figure 33. Belt mounts



- There may be local restrictions on use of belts.
- Individual information about the use of a belt must be received from the prescriber for each user.
- Be alert when using of positioning belt. There is a risk of the user sliding down in the chair and getting stuck in the belt if it is incorrectly installed or poorly fastened. This can lead to impaired blood or oxygen supply and risk of the user choking.
- Always make sure that the belt is securely fastened when in use.
- If possible, tighten the belt with the user in an upright position. If the belt is tightened when the back is reclined there is a risk of pinching when the back is raised up.
- Be aware of loose belts, they can get caught in the wheels and cause a sudden stop or pinching.

5. TRANSPORT

5.1 Folding the wheelchair for transportation

FOLDING OF WHEELCHAIR

- Tilt the seat unit to its most forward position.
- Remove the armrests and any accessories such as thoracic support and pommel, as well as cushions.
- Remove the leg rests (optional).
- Grasp the push bar with one hand and pull the locking pin, (1 in Figure 34). The gas spring (2) will then drop down from the mount (3) and the back can be folded forward against the seat, see Figure 35.
- The driving wheels may be removed to make the wheelchair smaller.

REASSEMBLY AFTER FOLDING

- Raise the back.
- Pull the locking pin (1), and fit the gas spring in the mount.
- Release the locking pin and see that it passes through the gas spring mounting hole and both plates of the bracket (3 in Figure 34).

CHECKLIST AFTER TRANSPORTATION:

- Make sure the locking pin (1) goes fully through the bracket (Figure 34).
- Check that the wheels are securely fastened.
- Make sure the tip protectors are positioned correctly.
- Check the most important functions; brakes, seat tilt, and back recline.



- If the pin is not properly mounted, the bracket can break and the user can be suddenly tipped backwards.

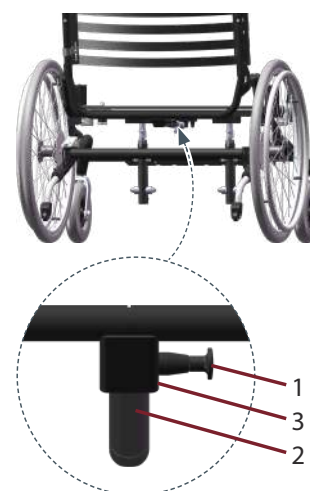

Figure 34. Locking pin for folding back rest

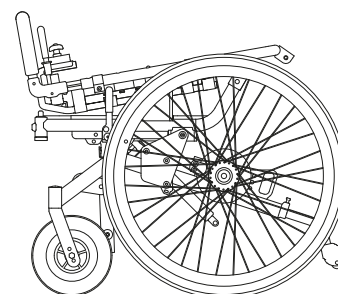

Figure 35. Folded wheelchair

5.2 Transferring in and out of the wheelchair

Transferring in and out of the wheelchair can be done in different ways **depending on the user's ability to actively participate**. It can be done with a lift (Figure 36), with help of one or two caregivers (Figure 37), or independently (Figure 38).

- The brakes must be locked before transferring in or out.
- Remove or fold in leg rests fully so they do not hinder. If needed foot plates can be folded up.
- Seat tilt and back recline may need to be adjusted per the particular needs of the user.
- Caregivers need to be mindful of their ergonomic positioning when assisting.

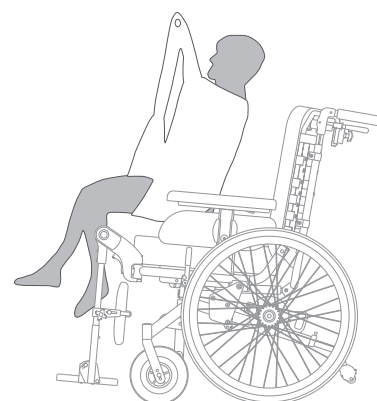

Figure 36. Transfer with lift

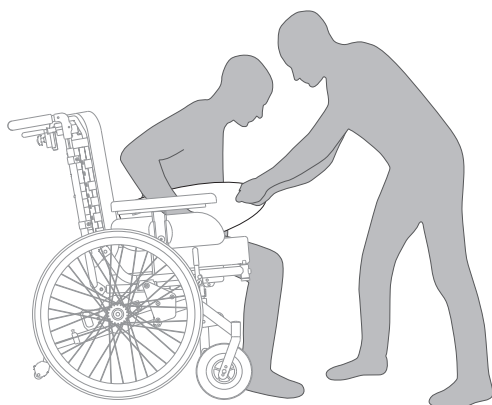

Figure 37. Transfer with assistance

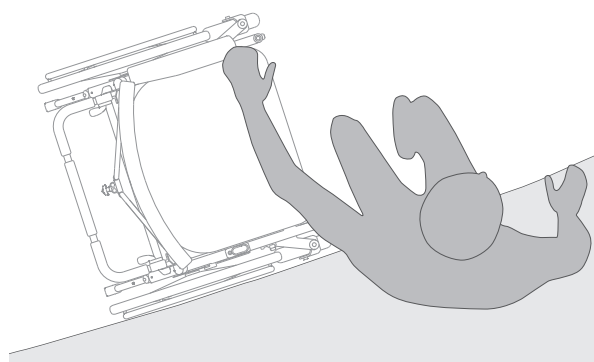

Figure 38. Independent transfer

5.3 Driving Technique

SLOPED SURFACES

When a user drives the wheelchair independently up a slope the wheelchair is balanced by the user leaning forward. When driving down a slope the user leans backward to balance the weight. Speed is controlled by using the hand rims.

On steeper slopes the wheelchair should be driven by a caregiver. Tip protectors must always be turned to the active position.

NOTE: Driving on sloped surfaces can be difficult with heavy users.

- Steep surfaces should be avoided due to the increased tipping risk.
- Surfaces that are wet, slippery, or uneven increase the risk of the wheelchair slipping or tipping.
- The wheelchair should not be turned on a sloped surface due to the increased tipping risk.
- When driving down a slope ensure that the user cannot slide out of the wheelchair (Figure 39).

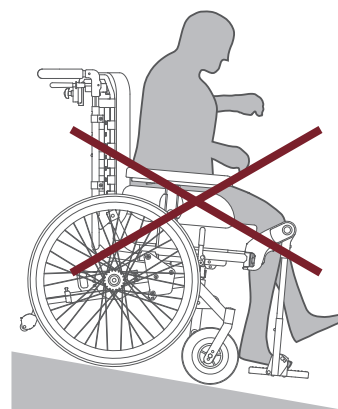

Figure 39. Sloped surface

CURBS / OBSTACLES - UPWARD WITH CAREGIVER

Tip the wheelchair up on the rear wheels by pushing down on the push bar and holding with one foot on the tip protector. Place the castors on the higher surface, lift on the push bar and roll the wheelchair up. See Figure 40.

NOTE: With a heavy user in the wheelchair it is not recommended to tip up the wheelchair due to the heavy load.

- As caregiver remember to use a good ergonomic position.
- In some cases it may be necessary to turn up the tip protectors, remember to turn them down again after moving.
- With a heavier user, tilt the seat back before tipping the wheelchair up. This reduces the amount of force required of the caregiver.

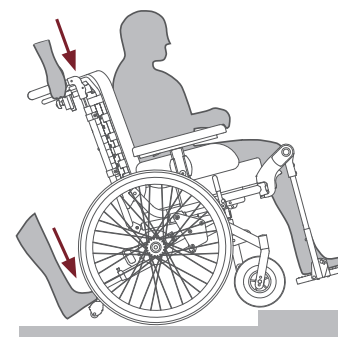

Figure 40. Curb

CURBS / OBSTACLES - DOWNWARD WITH CAREGIVER

Back the wheelchair carefully down the edge. Balance with the push bar until the castors have reached the lower surface.

- As caregiver remember to use a good ergonomic position.
- In some cases it may be necessary to turn up the tip protectors, remember to turn them down again after moving.



- The wheelchair is not to be transported on stairs.
- Never lift on the armrests or other unsecured parts.

6. MAINTENANCE AND CARE

For best safety and long life the wheelchair should be kept clean and tidy. Any faults and failures must be addressed immediately. Estimated lifetime is 10 years at normal use with the same patient during the whole lifetime and with maintenance carried out according to the instructions. How the chair is used affects the need for maintenance; hard wear, patients with particular movements, and much outdoor use require more maintenance and shorten the lifetime. Table 2 shows how maintenance should be carried out.

Table 2. Activity	Ongoing as necessary	1-2 times per year	At least every 3rd year
Cleaning of painted and coated surfaces and plastic parts	x		
Cleaning of cushion covers, see label in the cover	x		
Check of cushions and belts	x		
Checking all nuts and bolts		x	
Check of castor wheels		x	
Check of tip protectors		x	
Check of chassis		x	
Check of brakes		x	
Check of seat tilt and back recline functions		x	
Check of the back locking pin		x	
Check and maintenance of accessories (Functionality, lockings, markings)		x	
Total reconditioning			x

EXPLANATIONS FOR TABLE 2

COATED AND SURFACE TREATED SURFACES AND PLASTIC PARTS

- Wash/wipe with regular all-purpose detergent or disinfecting agents. No caustic agents.

SCREWS AND BOLTS:

- Check that the nuts and bolts are tight, tighten any that are loose.

CASTOR WHEELS:

- Check that the link wheels spin freely and do not have any visible damage. Remove any debris.

TIP PROTECTORS:

- Check that the tip protectors have no visible damage and are operating normally.

BRAKES:

- Check that the brakes work firmly (both operator and user brakes).

- Contact a qualified technician if adjustment is needed.

CHASSIS:

- Inspect the chassis for cracks, warping, and other defects. Notify authorized personnel if damaged.

TILT AND BACK RECLINE FUNCTIONS:

- Check that the controls are easy to use and that the levers do not have any damage.

BACK LOCKING PIN:

- Check that the locking pin is intact and sits properly. Make sure the knob is tightly screwed on.

CUSHIONS & BELTS:

- Cushions wear out and become compressed, check to see if any need replacing.

- Check that belt attachments, locking mechanisms, and velcro are working properly.

ARMRESTS, SIDE SUPPORTS AND CALF SUPPORTS:

- Wipe with damp cloth or with disinfectant.

ALUMINUM PROFILES with telescoping function can be lubricated with petroleum jelly or food grade grease.

6.1 Daily functional checks

To ensure user safety a daily functional check of the most vital parts should be carried out as follows:

- Test the brakes (both caregiver brake and user brake),
- Check the seat tilt and back recline functions.
- Check that the wheels and cushions are properly positioned and are well maintained and clean.
- Check that the tip protectors are in the appropriate position.

6.2 Long term storage

The wheelchair should be cleaned before storing long-term. Store in a dry, frost-free environment between 0 and 30°C. Cushions should be wrapped. When returning the wheelchair to service read through the user manual and check that all functions are working properly.

6.3 Recycling and disposal

HD Force can be largely recycled. Instructions for disassembly and recycling are available in *Disposal Instructions*, document number 97735-1.

7. TECHNICAL DATA - MEASUREMENTS

Measurement in cm unless otherwise noted	Seat width 54	Seat width 58	Seat width 62
Maximum user weight [kg]	180	180	180
Seat width	54	58	62
Seat depth (with back cushion)	43 - 52	43 - 52	43 - 52
Seat depth (without back cushion)	48 - 57	48 - 57	48 - 57
Seat height with / without seat cushion	52 / 45	52 / 45	52 / 45
Backrest height standard, seat plate - top of backrest	55 - 60	55 - 60	55 - 60
Backrest height long, seat plate - top of backrest	65 - 70	65 - 70	65 - 70
Back width	54	58	62
Armrest height Standard, from seat plate	26 - 36	26 - 36	26 - 36
Armrest height Low, from seat plate	20 - 26	20 - 26	20 - 26
Armrest pad - length x width	37 x 7	37 x 7	37 x 7
Leg rest length short, seat plate - footrest, leg 90°	21 - 27	21 - 27	21 - 27
Leg rest length standard, seat plate - footrest, leg 90°	29 - 43	29 - 43	29 - 43
Leg rest length long, seat plate - footrest, leg 90°	37 - 51	37 - 51	37 - 51
Leg rest angle [°]	90 - 180	90 - 180	90 - 180
Footrest angle leg rest tube - foot plate [°]	90 - 110	90 - 110	90 - 110
Footrest plate length	22	22	22
Push bar height, standard, 3 positions	105, 113, 120	105, 113, 120	105, 113, 120
Total width 22" drive wheels	79	83	87
Total width 16" drive wheels	78	82	86
Total length, with leg rests	101	101	101
Total length, without leg rests	77	77	77
Total height, seat 0°, back 90°	105	105	105
Total height, back and push bar folded, w/o cushions	75	75	75
Seat angle [°]	0 - 20	0 - 20	0 - 20
Back angle [°]	90 - 120	90 - 120	90 - 120
Total weight with caregiver brakes, cushions, Separate leg rests, Standard armrests [kg]	40,7	41,0	41,3
Transport measurements (collapsed, including brakes, w/o drive wheels, leg rests, armrests, cushions)			
Width	79	83	87
Length	82	82	82
Height	71	71	71
Weight [kg]	24,3	24,5	24,7



 **rehab**

 **HD Rehab AB**
Tryffelsslingan 4
181 57 Lidingö
SWEDEN

+46 - 8 - 767 04 80

info@hdrehab.se

www.hdrehab.com

Doc. nr. 97701-1
User Manual
HD Force
Rev A 2023-09-20

